

Z 2

MEC

( mechanical feed )

ardor = 1.4 kg  
 tool = 2.1 kg  
 total = 3.5 kg

Subrack data (estimated figure)

Effort rotation speed: 7600 U/min. ( ca. 40m / Sek. - small diameter )  
 max. rotation speed: 11700 U/min.  
 Feed rate: 4 (end grain) - 8 (along) m/min.  
 Rotation: RH - against the feed

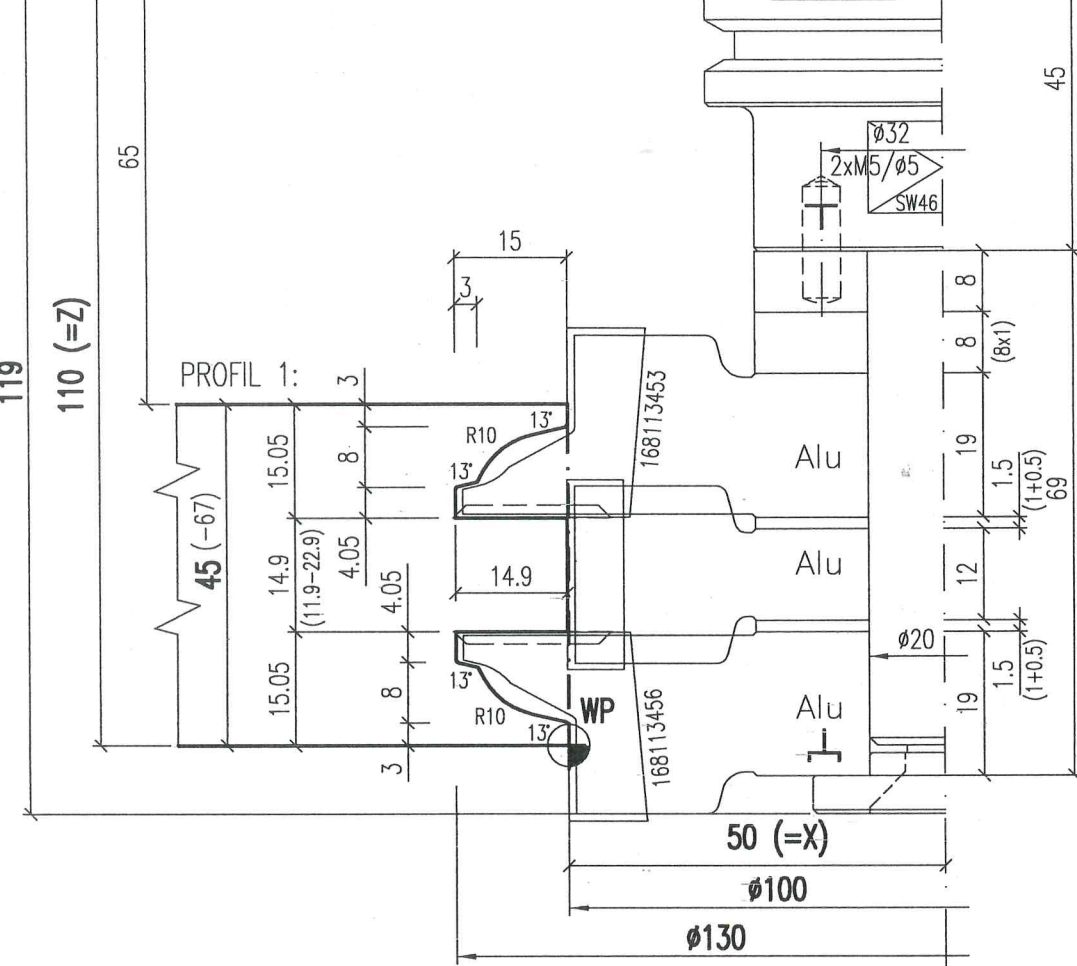

165231642  
 (42987 umarbeiten)  
 HSK-F63, SPD 20  
 SPH 65

WE 500 2 50 130x25xBo.  
 168113452 2E25/15+2VS2

WW 211 2 NN 100.2x25xBo.  
 168113454 2WP8/25B

WE 500 2 50 130x25xBo.  
 168113455 2E25/15+2VS2

profilcut knives available

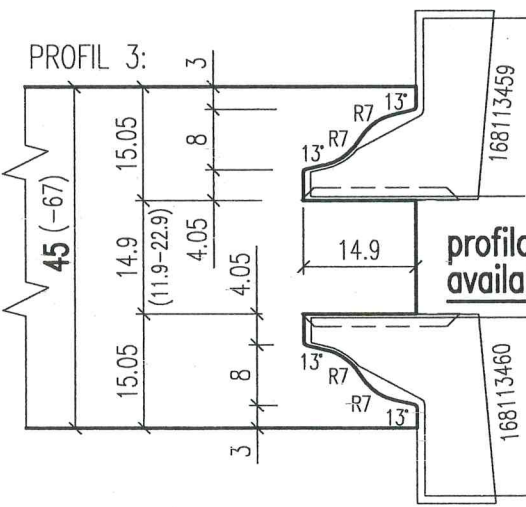
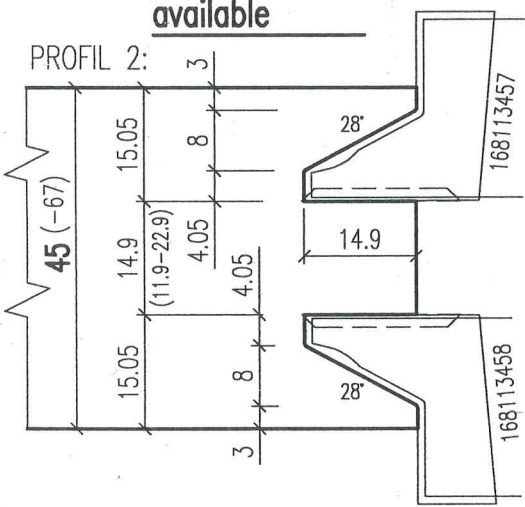

profilcut knives available

MP = Maschinennullpunkt  
 WP = Werkzeugnullpunkt

PROTECTION DIN 34-1-1 D	2007	Date	Name	<b>leitz</b>	Plant A-4752 RIEDAU AUSTRIA	Replacement for
	drw.	29.01.	AUD			previous Leitz-No.
TOLERANCES to LEITZ - WERKNORM	exa.	29.01.	AUD	Article-No. SG 599-2 50		
	det.			Ident-No. L 168113441 SA01		
TOOL QUAL. HW	<b>"ProfilCut" - Cutterset</b>					
SCALE 1:1						Cross section